

OWS Alarm Installation Manual

P/N #S/OWS/HOLS/30X

OWS Alarm:

Features: OWS Alarm is a liquid monitoring alarm system that will alert when oil is sensed on water. The sensor will provide accurate capacitive measurement of water in tanks where oil is not normally present. In the event that oil is separated to the water surface at the sensor's fixed location, the alarm system will notify that there is an accumulation of oil.

- Indoor/Outdoor NEMA 4X enclosure: heavy duty polycarbonate enclosure with stainless steel lockable Latches
- Includes Oil Water Separator Sensor with 30' oil resistant cord
- Alarm visible indicators: red beacon alarm light, alarm test and silence buttons
- Alarm horn sounds at 85 decibels at 10 feet
- LED 22.5 mm indicators: low level alert and power on
- Includes auxiliary contacts to communicate with Oil Separator and remote devices.
- 120VAC, 10' power cord
- Panel and controls: UL listed for The United States and Canada

Additional panel options:

C = Additional cord length greater than 30'
specify after C
Example: OWS-C50 Indicates 50' cord

 **WARNING**

1. All installations must be in accordance with the National Electrical Code, and any other applicable state and local electrical requirements.

Service:

Caution: Before checking electrical connections within the control or attempting to replace any components, turn off all branch circuits supplying power to the main control panel.

Panel Installation:

1. Determine mounting location for control panel. Mount panel using mounting hardware supplied.
2. **The control panel should not be mounted in an area that is subject to submersion.**
3. Run sensor cable through conduit. Make appropriate field connections.
4. Branch circuit protection to be provided by contractor.
5. **Sensor cable require separate conduit from power and pump cables.**
6. Mount sensor at appropriate levels. Be sure that the Sensor has a free range of motion to prevent entanglement.

Start up:

1. When the power is applied, the green power light shall illuminate.
2. To test the alarm circuit, push the test button on the front panel, the audible alarm shall sound and the red LED will light. Press the silence button to silence the alarm.

TYPICAL INSTALLATION OF OWS ALARM :

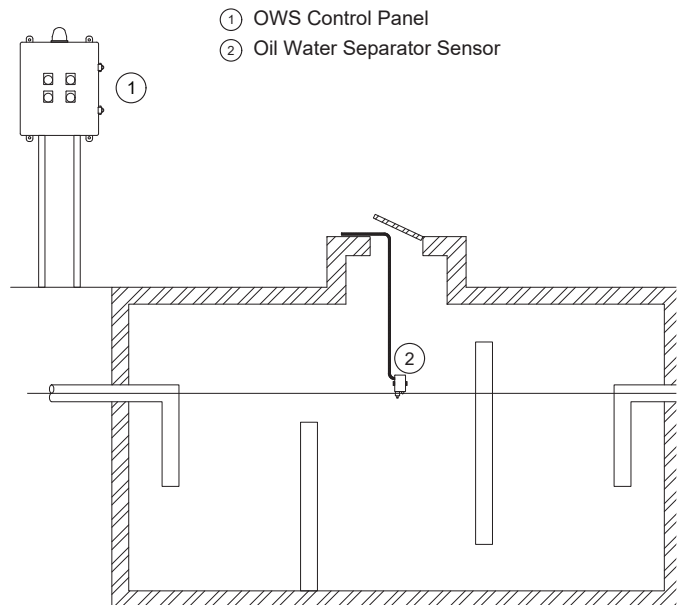

www.skimoil.com
314-579-9755 • Email: info@skimoil.com
103 West Weaver St., Suite 2D
Carrboro, NC 27510

SKIM OIL®
INC.

REVDATE: 0725 FNAME: OWS

REVISIONS				
ZONE	REV	DESCRIPTION	DATE	APPROVED

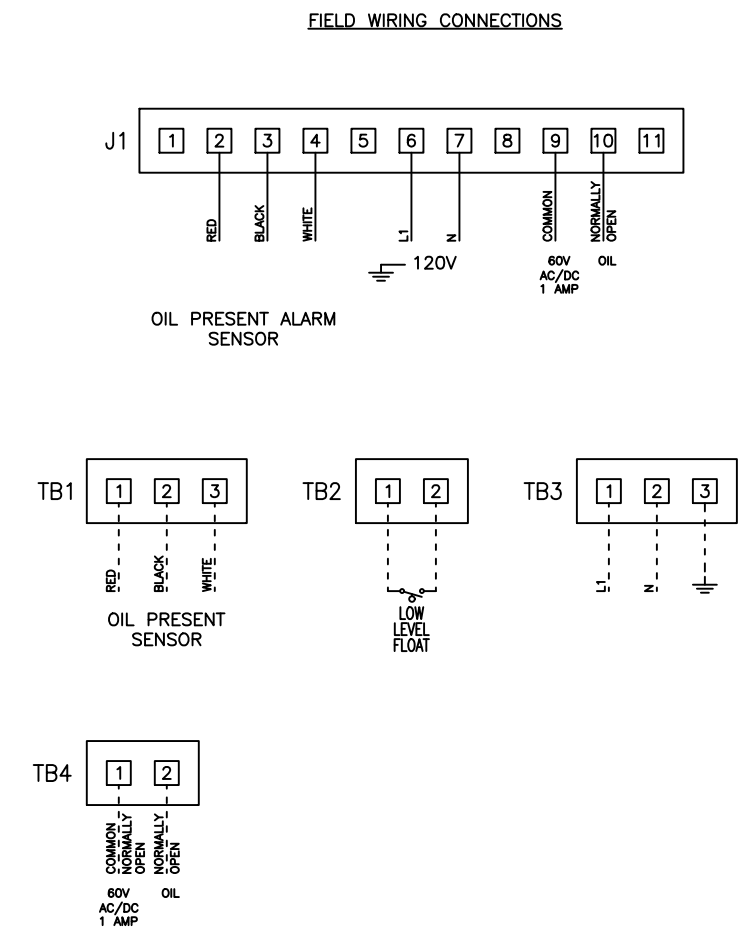
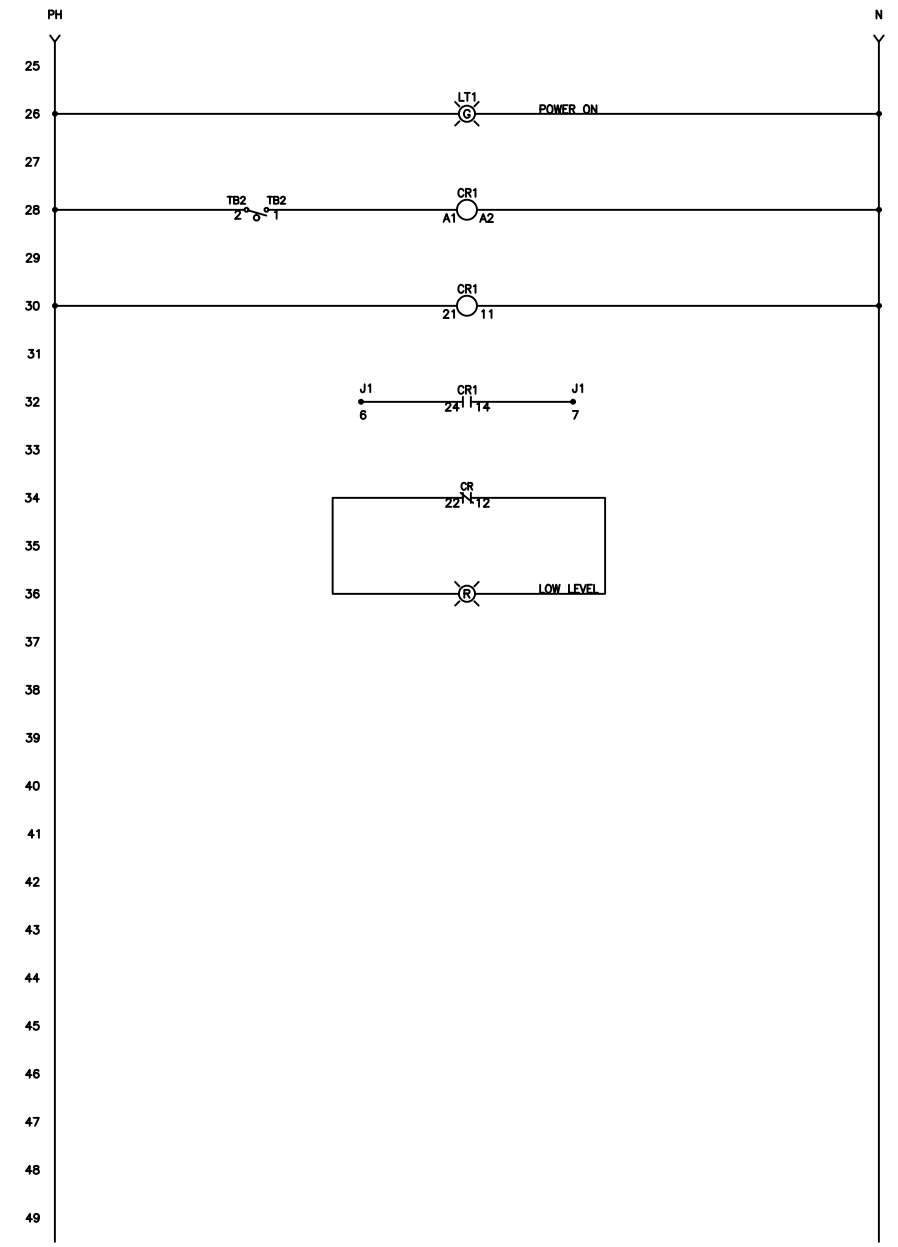
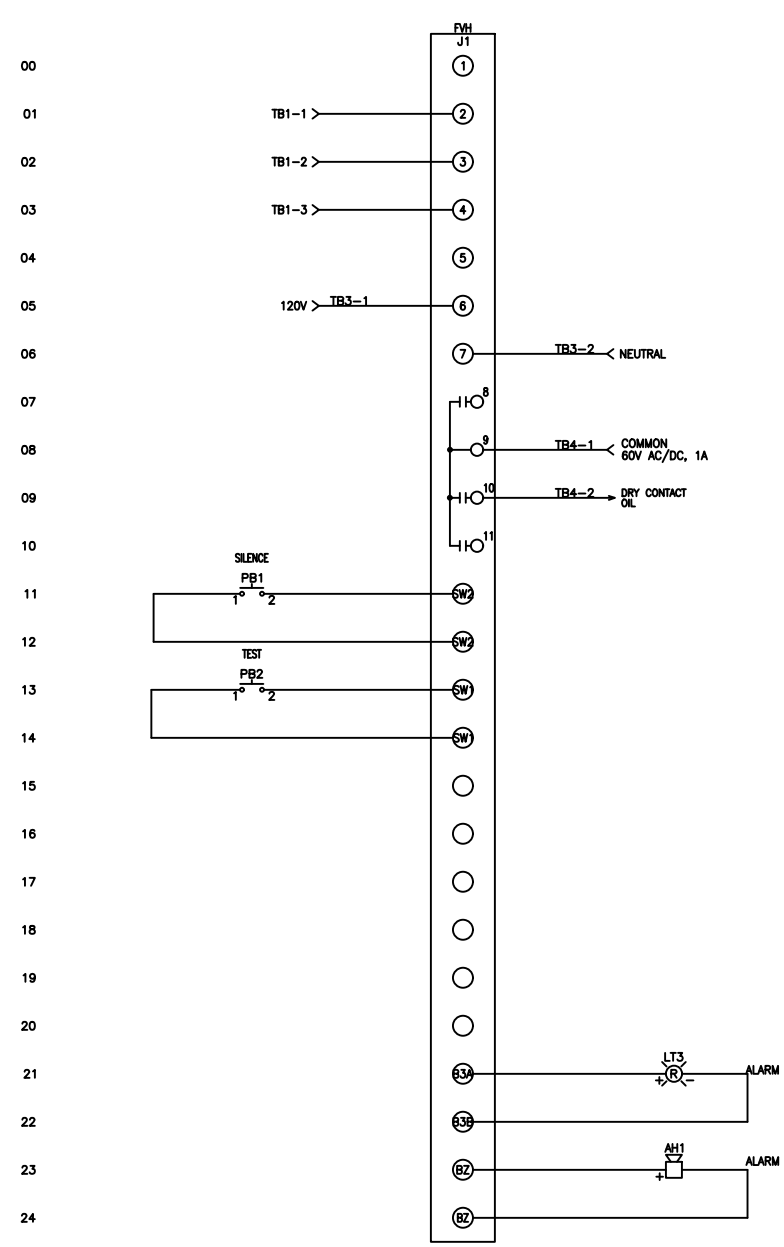

----- DASHED LINE INDICATES FIELD WIRING.

USE COPPER CONDUCTORS ONLY.
 TEMPERATURE RATING OF CONDUCTORS IS TO BE 60°C (167°F).
 BRANCH CIRCUIT PROTECTION SHALL BE PROVIDED BY THE INSTALLER. MUST BE SIZED ACCORDING TO PUMP/MOTOR MANUFACTURING SPECIFICATIONS.
 VERIFY CORRECT OPERATION OF CONTROL PANEL AFTER INSTALLATION IS COMPLETE.

DRAWN BY:	DATE: 7/25/18	SKIMMOIL INC.			
APPROVED BY:	DATE:				
THIS DRAWING CONTAINS PROPRIETARY INFORMATION AND SHALL NOT BE USED OR DISCLOSED WITHOUT PRIOR WRITTEN AUTHORIZATION.		TITLE: OWS CONTROL SCHEMATIC			
		SIZE B	DWG NO. 00	PART NO. #S/OWS/HOLS/30X	REV
		SCALE NONE	SHEET 1 OF 1		